

Type H9N Load Cell

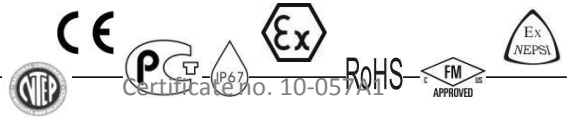

Short description

Nickel plated alloy steel IP67 dual shear beam load cell
High accuracy
Suitable for truck and track scales and other heavy weighing devices
Sealed construction



Available models

Capacity	Accuracy	Full article description
25Klb	D3	H9N-D3-25K-9B
40Klb	D3	H9N-D3-40K-9B
50Klb	D3	H9N-D3-50K-9B
60Klb	D3	H9N-D3-60K-9B
75Klb	D3	H9N-D3-75K-9B
100Klb	D3	H9N-D3-100K-9B
125Klb	D3	H9N-D3-125K-9B
150Klb	D3	H9N-D3-150K-9B
200Klb	D3	H9N-D3-200K-9B

Specifications and dimensions are subject to change without notice and do not constitute any liability whatsoever.

Type H9N Load Cell

Detailed specifications H9N

Accuracy class		D3		
Output sensitivity (= FS)	mV/V	3.0 ± 0.003		
Maximum capacity (E _{max})	Klb	25, 40, 50, 60, 75, 100, 125, 150, 200		
Max.number of load cell intervals	n _{LC}	10000		
Ratio of min. LC verification interval	$Y = E_{max} / v_{min}$	7500		
Combined Error	%FS	≤± 0.03		
Minimum dead load	Of E _{max}	0%		
Safe overload	of E _{max}	150 %		
Ultimate overload	of E _{max}	300 %		
Zero balance	of FS	< ± 1.0 %		
Excitation, recommended voltage	V	5 ~ 12		
Excitation maximum	V	18		
Input resistance	Ω	700 ± 7		
Output resistance	Ω	703 ± 4		
Insulation resistance	MΩ	≥5000 (at 50VDC)		
Compensated temperature	°C	-10 ~ +40		
Operating temperature	°C	-35 ~ +65		
Storage temperature	°C	-40 ~ +70		
Element material		Nickel plated alloy steel		
Ingress Protection (acc. to EN 60529)		IP67		
ATEX classification (optional)		II1G Ex ia II1C T4	II1D Ex iaD 20 T73°C	II3G nL IIC T4

Wiring

Wiring:

Shielded, 4 conductor cable.

Cable diameter for 5k – 20k: Ø5mm and for 30k – 250k: Ø8mm.

Standard cable length: 9m.

Shield not connected to element.

4-wire diagram

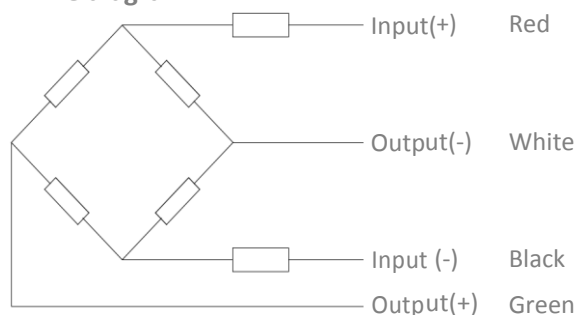

Specifications and dimensions are subject to change without notice and do not constitute any liability whatsoever.

Type H9N Load Cell

Dimensions in mm

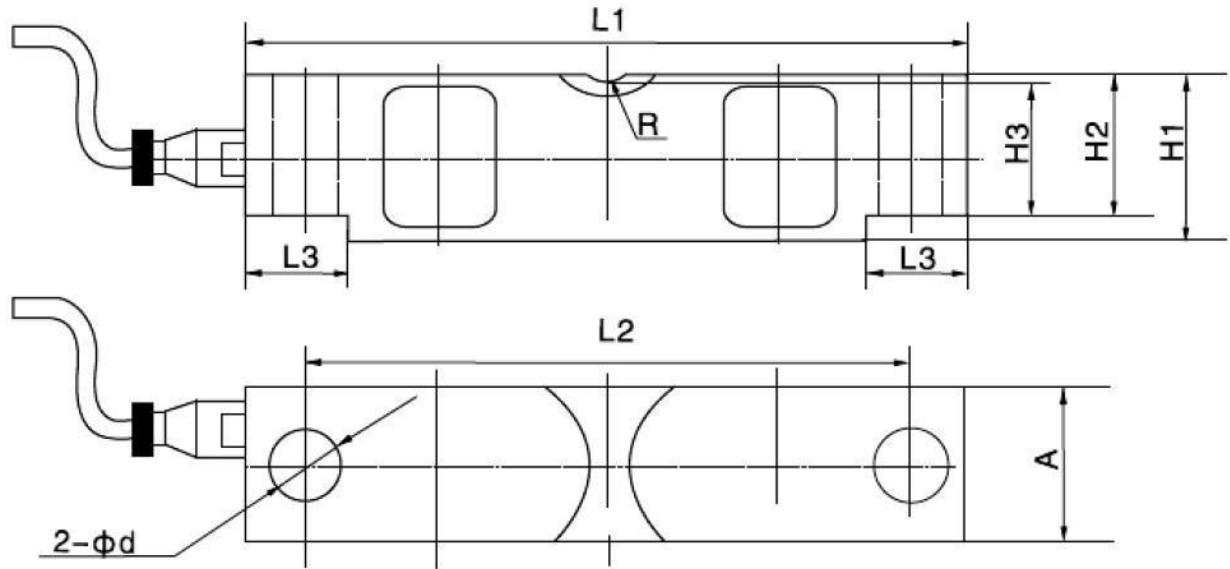

Dimension Capacity	L1	L2	L3	H1	H2	H3	A	Ød	R
25Klb	197	165	35	49.3	43.2	41.4	43	17.3	19.1
40Klb	260.4	216	49.3	62	53.3	50.8	49.3	20.6	25.4
50Klb-75Klb	260.4	216	49	74.7	67.3	64.5	62	26.9	25.4
100Klb-125Klb	387.4	324	79.5	98	87.1	83.8	73.7	41.2	38.1
150Klb, 200Klb	489	387.4	127.8	147.3	130.1	112.8	96.5	41.2	50.8

Specifications and dimensions are subject to change without notice and do not constitute any liability whatsoever.