

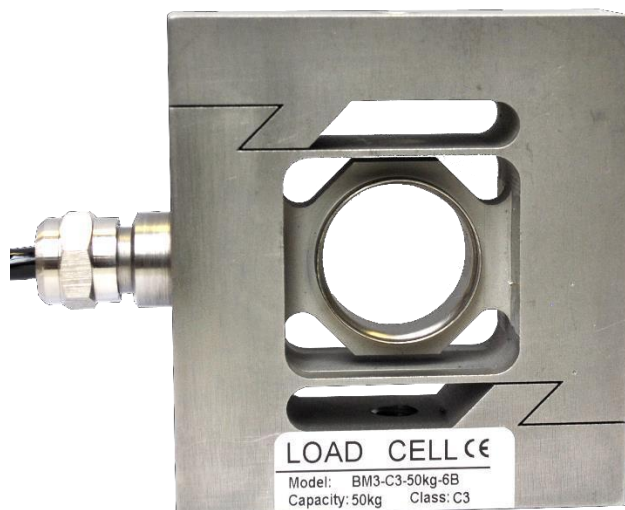

Type BM3 Load Cell



Short description

- Stainless steel IP68 "S" type load cell
- Tension and compression applications
- Suitable for hanging, hopper and other weighing devices



 test certificate no. D09-08.01
C of C no R60/2000-DE1-10.08

 Certificate no. 06-099A1

Available models

Capacity	Accuracy	Full article description
50kg	C3 Excluded from OIML	BM3-C3-50kg-6B
100kg	C3 Excluded from OIML	BM3-C3-100kg-6B
150kg	C3 Excluded from OIML	BM3-C3-150kg-6B
200kg	C3 Excluded from OIML	BM3-C3-200kg-6B
250kg	C3 Excluded from OIML	BM3-C3-250kg-6B
0.5t	C3	BM3-C3-0.5t-3B
1t	C3	BM3-C3-1t-6B
2t	C3	BM3-C3-2t-6B
3t	C3	BM3-C3-3t-6B
4t	C3	BM3-C3-4t-6B
5t	C3	BM3-C3-5t-6B
6t	C3	BM3-C3-6t-6B
7.5t	C3	BM3-C3-7.5t-6B

Specifications and dimensions are subject to change without notice and do not constitute any liability whatsoever.

Type BM3 Load Cell

Detailed specifications BM3

Accuracy class		C3	OIML R60 C3	
Output sensitivity (= FS)	mV/V	2.0 ± 0.008	2.0 ± 0.004	
Maximum capacity (E _{max})	t	0.05, 0.1, 0.15, 0.2, 0.25	0.5, 1, 2, 3, 4, 5, 6, 7.5	
Max.number of load cell intervals	n _{LC}	3000		
Ratio of min. LC verification interval	$Y = E_{max} / V_{min}$	7500	12000	
Combined Error	%FS	≤± 0.0230		
Minimum dead load	Of E _{max}	0%		
Safe overload	of E _{max}	150 %		
Ultimate overload	of E _{max}	300 %		
Zero balance	of FS	< ± 1.5 %		
Excitation, recommended voltage	V	5 ~ 12		
Excitation maximum	V	18		
Input resistance	Ω	350 ± 3		
Output resistance	Ω	350 ± 3		
Insulation resistance	MΩ	≥5000 (at 50VDC)		
Compensated temperature	°C	-10 ~ +40		
Operating temperature	°C	-35 ~ +65		
Storage temperature	°C	-40 ~ +70		
Element material		Stainless steel		
Ingress Protection (acc. to EN 60529)		IP68		
ATEX classification (optional)		II1G Ex ia II1C T4	II1D Ex iaD 20 T73°C	II3G nL IIC T4

Wiring

Wiring:

Shielded, 4 conductor cable.

Cable diameter: Ø5mm

Standard cable length for 500kg:3m and for all other capacities: 6m.

Shield not connected to element

4-wire diagram

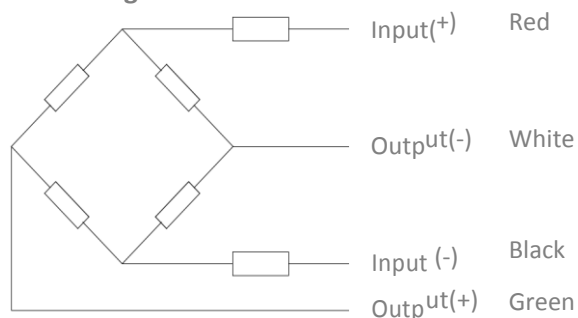

Specifications and dimensions are subject to change without notice and do not constitute any liability whatsoever.

Type BM3 Load Cell

Dimensions in mm

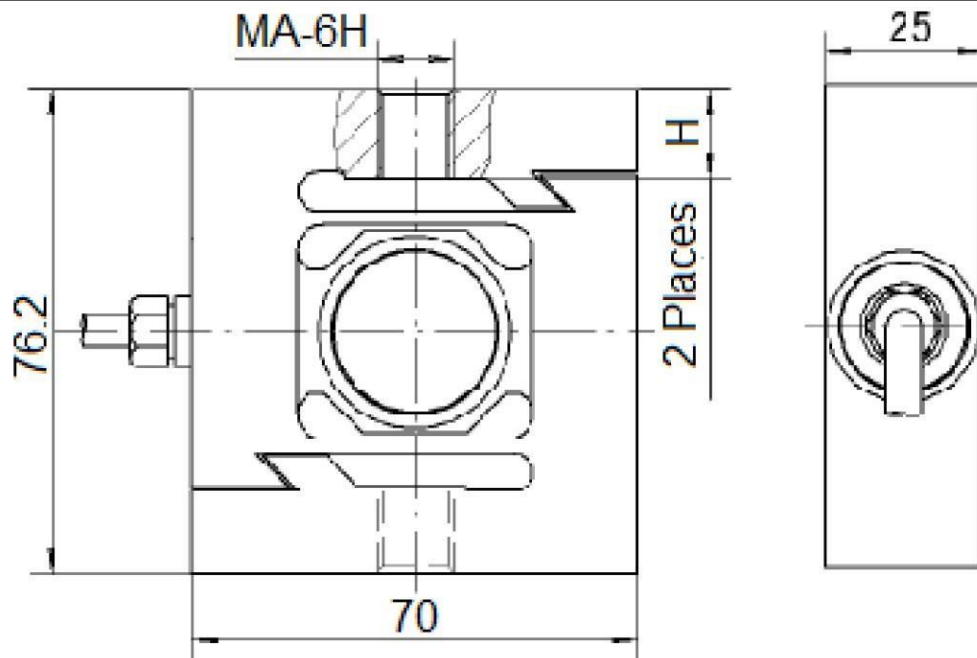

Dimension Capacity	MA	H
50kg, 100kg	M8	13
150kg - 250kg	M12 x 1.75	14

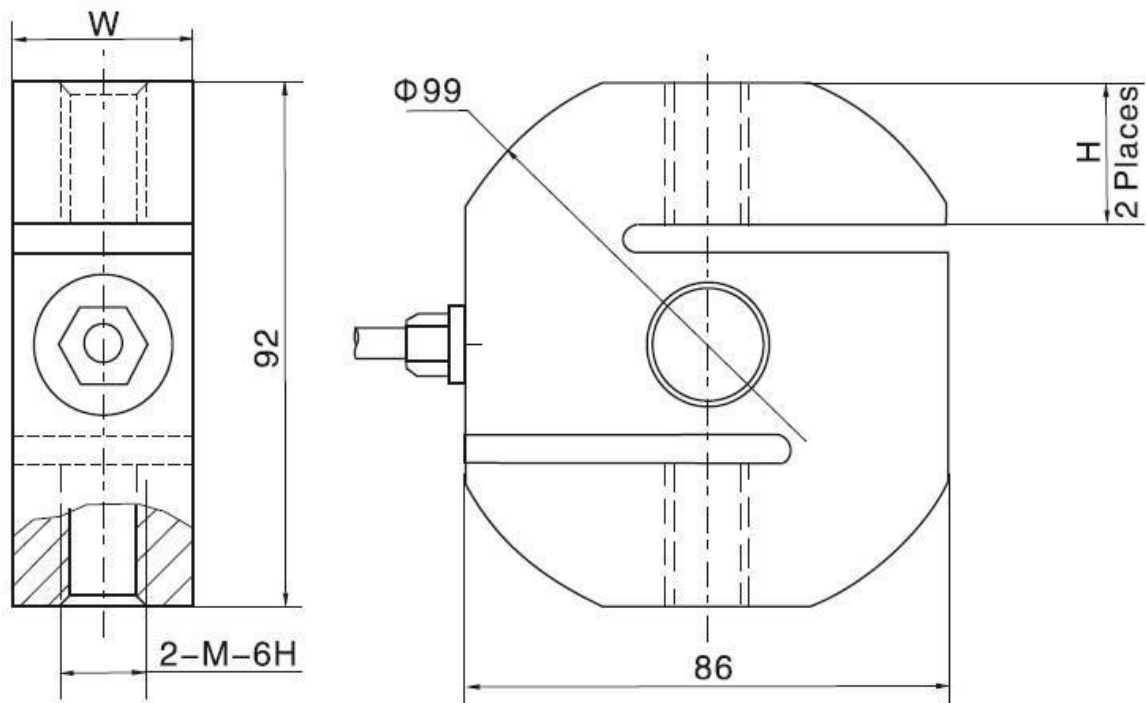

Dimension Capacity	W	H	M
0.5t, 1t	32	25	M12 x 1.75
2t, 3t	32	25	M20 x 1.5
4t	36	25	M20 x 1.5
5t, 6t, 7.5t	50	24	M24 x 2

Specifications and dimensions are subject to change without notice and do not constitute any liability whatsoever.

Type BM3 Load Cell

Available accessories

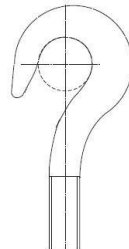
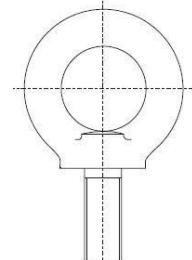
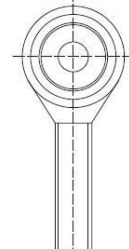
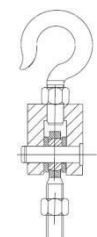
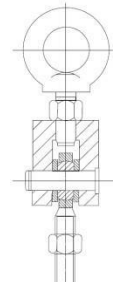
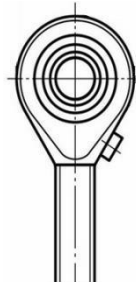
<p>HL-3-001-25kg-4t hook</p> <ul style="list-style-type: none">• Alloy steel• Suitable for hybrid scales, crane scales, packaging scales and hopper scales	
<p>HL-3-002-0.025-4t eye</p> <ul style="list-style-type: none">• Alloy steel• Suitable for hybrid scales, crane scales, packaging scales and hopper scales	
<p>HL-3-003-0.025-7.5t rod end</p> <ul style="list-style-type: none">• Alloy steel• Suitable for hybrid scales, crane scales, packaging scales, hopper scales and other electronic weighing devices.	
<p>HL-3-004-0.025-3t hook assembly</p> <ul style="list-style-type: none">• Alloy steel• Suitable for hybrid scales, crane scales, packaging scales, hopper scales and other electronic weighing devices.	
<p>HL-3-005- 0.025-4t eye assembly</p> <ul style="list-style-type: none">• Alloy Steel• Suitable for hybrid scales, crane scales, packaging scales, hopper scales and other electronic weighing devices.	
<p>HL-3-007- 5t rod end</p> <ul style="list-style-type: none">• Alloy Steel• Suitable for hybrid scales, crane scales, packaging scales, hopper scales and other electronic weighing devices.	

Specifications and dimensions are subject to change without notice and do not constitute any liability whatsoever.